

# EXTENDED COVERAGE

## Ordinary Hazard Standard Response Sprinkler Recessed Pendent, Pendent and Upright

### DESCRIPTION:

The upright and pendent sprinkler model GFR VELO-ECOH extended Coverage Sprinkler has a very extra large orifice with a nominal K=14 (200). It can provide Ordinary Hazard Group 1 and 2 Occupancies to 400 ft<sup>2</sup> (37.2 m<sup>2</sup>) per sprinkler when the system is designed to NFPA 13 hydraulic density requirements. These sprinklers are to be installed according to the design criteria shown in this data sheet. The use of ECOH sprinklers can provide lower system installation costs by requiring fewer sprinklers, less piping and reduced labor.



### TECHNICAL DATA:

Nominal "K" Factor	14 (200 metric)
Thread Size	3/4" NPT (R3/4)
Nominal Orifice	0,70" (18 mm)
Temperatures	165°F (74°C) 212 °F (100°C)
Minimum Sprinkler Spacing	12 ft (3,6 m)
Maximum Sprinkler Spacing	20 ft (6,1 m)
Coverage Area	400 ft <sup>2</sup> (37,2 m <sup>2</sup> )
Minimum operational area	1500 ft <sup>2</sup> (139,4 m <sup>2</sup> ) or 5 sprinklers, whichever is greater
Minimum distance between deflector to commodity clearance	18" (457 mm)
In sloping ceilings	Not exceeding 2" (50,8 mm) of rise in 1 ft (0,3 m)
Maximum Operating Pressure	175 psi (12 bar)
Finishes <sup>(1)</sup>	Bronze, Chrome and Polyester Coated

Data sheet:	08
REV:	00



MINIMUM FLOW REQUIREMENTS		NFPA 13-1991 and later				NFPA 13-1989 and earlier					
		Ordinary Hazard 1		Ordinary Hazard 2		Ordinary Hazard 1		Ordinary Hazard 2		Ordinary Hazard 3	
		0.15gpm/ps <sup>2</sup> (6.1L/min/m <sup>2</sup> ) Density		0.20gpm/ps <sup>2</sup> (8.1L/min/m <sup>2</sup> ) Density		0.16gpm/ps <sup>2</sup> (6.5L/min/m <sup>2</sup> ) Density		0.19gpm/ps <sup>2</sup> (7.5L/min/m <sup>2</sup> ) Density		0.21gpm/ps <sup>2</sup> (8.25L/min/m <sup>2</sup> ) Density	
		Flow	Pressure	Flow	Pressure	Flow	Pressure	Flow	Pressure	Flow	Pressure
Spacing (1)	Coverage area	gpm (L/min)	psi (bar)	gpm (L/min)	psi (bar)	Gpm (L/min)	psi (bar)	gpm (L/min)	psi (bar)	gpm (L/min)	psi (bar)
20' x 20' (6.1m x 6.1m)	400 ps <sup>2</sup> (37.2 m)	60.0 (227)	18.4 (1.3)	80.0 (302)	32.7 (2.3)	64.0 (242)	20.9 (1.5)	76.0 (287)	29.5 (2.1)	84.0 (318)	36.0 (2.5)

### Location of deflector to obstruction

Distance from Sprinkler to side of obstruction	Maximum allowable distance deflector above bottom of obstruction (inches)
Less than 1"	0"
1" to less than 1"-6"	0"
1"-6" to less than 2"	1"
2" to less than 2"-6"	1"
2"-6" to less than 3"	1"
3" to less than 3"-6"	3"
3"-6" to less than 4"	3"
4" to less than 4"-6"	5"
4"-6" to less than 5"	7"
5" to less than 5"-6"	7"
5"-6" to less than 6"	7"
6" to less than 6"-6"	9"

Data sheet:	08
REV:	00



### OPERATION:

The sprinkler model GFR VELO-ECOH uses a central link with compression weld. The fusible is captured in the capsule cylinder through a stainless steel ball. When the fusible melts, the ball displaces through the cylinder, allowing the cylinder to separate from the central link. When it occurs, the lever is liberated and it removes from the sprinkler, this way all the operating items unblock the water way and allow the deflector to distribute the water discharge.

### INSTALLATION:

Model GFR VELO-ECOH sprinklers are designed for installation as specified in NFPA 13. They must also be installed with the Model AG3 (for Pendent and Upright sprinklers) and XLO (for Recessed Pendent sprinklers)..

The sprinkler joint can be obtained with a torque of 14-20 ft-lbs (19-27,1 N-m). Do not tighten sprinklers over maximum recommended torque. It may cause leakage or impairment of these sprinklers.

### TEMPERATURE RATING:

Classification	Nominal Sprinkler Temperature		Maximum Ceiling Temperature	
	°F	°C	°F	°C
Pendent and Upright	165	74	100	38
Recessed pendent <sup>(2)</sup>	212	100	150	66

### DIMENSIONS:

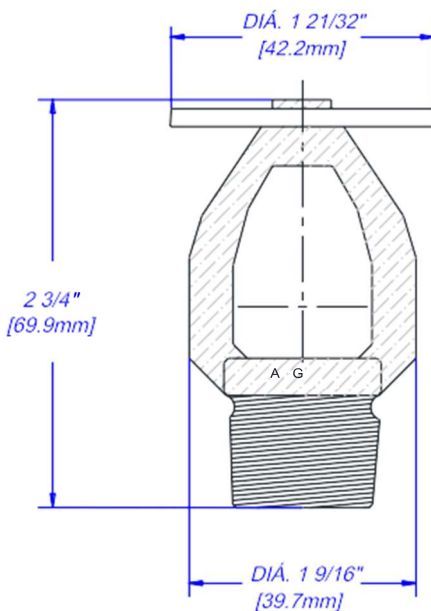

UPRIGHT

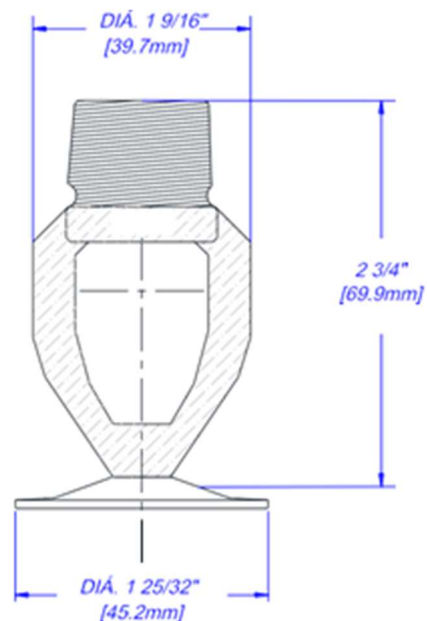

PENDENT

Data sheet:	08
REV:	00



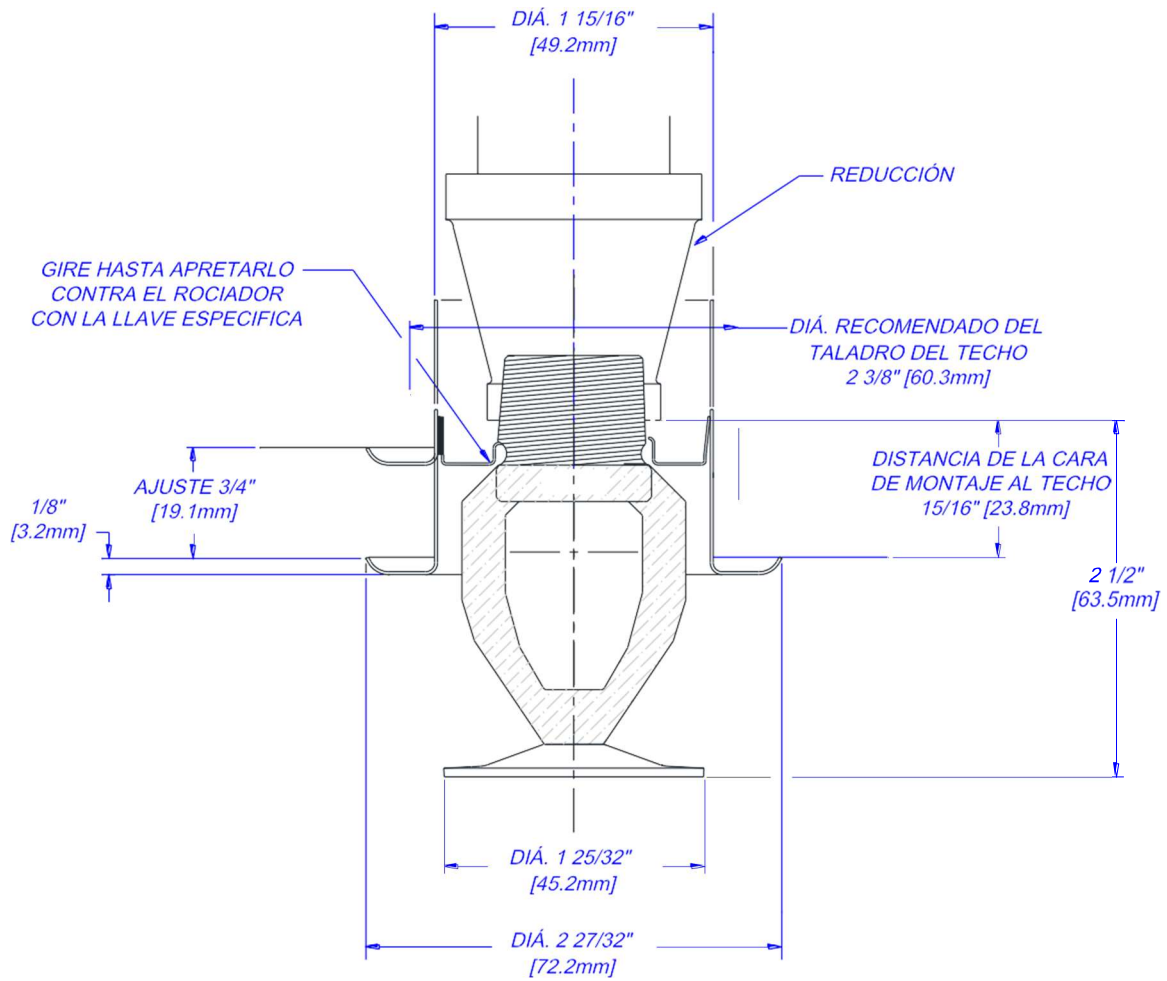

RECESSED PENDENT WITH ESCUTCHEON

Data sheet:	08
REV:	00