

# STANDAR COVERAGE

## Basic Sprinkler Standard Response Sprinkler Recessed Pendent, Pendent & Upright



### DESCRIPTION:

AG-81, Pendent and Upright sprinklers described in this technical data sheet are standard response, standard coverage 5 mm glass bulb. These sprinklers are designed for use in commercial buildings and factories.

Thermosensitive glass bulb 5 mm is used. The bulb contains a special liquid hermetically sealed in a glass capsule.

### TECHNICAL DATA:

Nominal "K" Factor	8,0 (115)
Thread Size	3/4" NPT (R3/4)
Nominal Orifice	17/32" (20 mm)
Temperatures	135°F (57°C) 155°F (68°C) 175°F (79°C) 200°F (93°C) 286°F (141°C) 360°F (182°C)
Maximum / Minimum Working Pressure	175 psi (12,1 bar) / 7 psi (0,48 bar)
Factory tested Pressure	500 psi (34,5 bar)
Materials	Frame: Brass Deflector: CDA Alloy 510 Screw: CDA Alloy 210, 220, 314, 316, 360 or 544 Cup: CDA Alloy 314 or 353 Washer: Nickel Alloy 440 or Alloy CDA 360 Bulb: Glass, 5 mm
Finishes <sup>(4)</sup>	Bronze Chrome Polyester coated

Data sheet:	13
REV:	00

### OPERATION:

At normal temperatures, the glass bulb contains the fluid in both the liquid phase and the vapor phase. The vapor phase can be seen as a small bubble. As heat is applied, the liquid expands forcing the bubble smaller and smaller as the liquid pressure increases. Continued heating forces the liquid to push out against the bulb, causing to shatter, opening the waterway and allowing the deflector to distribute the discharging water.

### INSTALLATION:

Model AG-81 sprinklers are standard response sprinklers intended for installation as specified in NFPA13. They must also be installed with the Model AG1 Sprinkler Wrench for pendent and upright models, and the AG2 Sprinkler Wrench for the recessed model

A leak tight ½" NPT (R1/2) sprinkler joint can be obtained with a torque of 8-18ft-lbs (10.8- 24.4N-m). Do not tighten sprinklers over maximum recommended torque. It may cause leakage or impairment of these sprinklers.

The sprinklers come with an orange protection, to avoid breakage during assembly. Remove this protection once installed and made sure that everything is correct.

### TEMPERATURE RATING:

Classification	Nominal Temperature		Máxima Ambient Temperature		Bulb Color
	°F	°C	°F	°C	
Ordinary	135	57	10 0	38	Orange
Ordinary	155	68	10 0	38	Red
Interme diate	175	79	15 0	66	Yellow
Interme diate	200	93	15 0	66	Green
High <sup>(1)</sup>	286	141	22 5	107	Blue
Very high <sup>(1)</sup>	360	182	30 0	149	Mauve

<b>Data sheet:</b>	13
<b>REV:</b>	00



## DIMENSIONS:

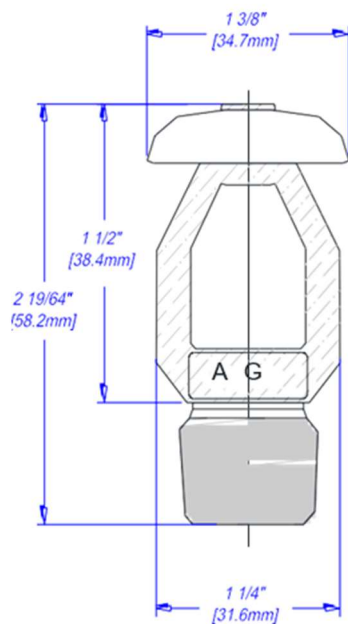

**UPRIGHT**

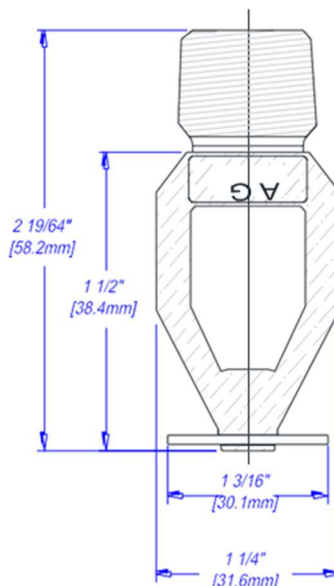

**PENDENT**

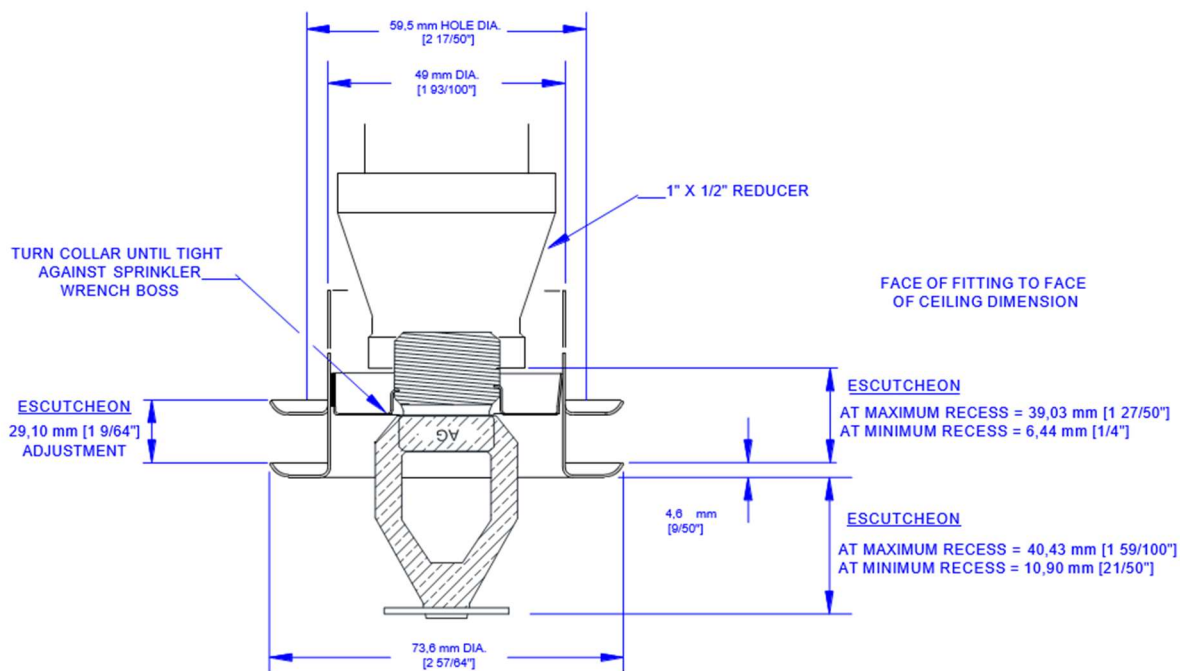

**RECESSED PENDENT**

<b>Data sheet:</b>	13
<b>REV:</b>	00