

STORAGE

Suppression Mode Fast Response (ESFR) Pendent

DESCRIPTION:



The early suppression fast response (ESFR), Model AG-17 designed to respond quickly to growing fires with a high volume of water discharge to “suppress” rather than “control” fires.

The ESFR sprinkler model AG-17 is UL Listed Specific Application Criteria to Protect Class I

- IV commodity and Cartoned Unexpanded Group A plastics stored up to 43 ft (13.1 m) in a

48 ft (14,6 m) building, with a minimum aisle width of 8ft (2,44 m). Permitted Storage Arrangements: Single- and double-row rack storage (no open top containers or solid shelves) and palletized and solid pile storage (no open top containers or solid shelves). Minimum System Operating Pressure: 55 psi (3,79 bar).

TECHNICAL DATA:

Nominal “K” Factor	16,8 (241,9)
Thread Size	3/4" (R3/4)
Temperatures	165°F (74°C) 212°F (100°C) ⁽¹⁾
System Type	Wet Pipe systems only
Maximum / minimum area of coverage	100 ft ² (9,3 m ²) / 64 ft ² (5,8 m ²)
Maximum slope ceiling	2/12 (9,5°)
Maximum spacing	12 ft (3,7 m) for building heights up to 30 ft (9,1 m) 10 ft (3,1 m) for building heights greater than 30 ft (9,1 m)
Minimum spacing	8 ft (2,4 m)
Deflector distance from walls	At least 4" (102mm) / no more than 1/2 the allowable distance permitted between sprinklers
Deflector to top storage	36" (914 mm)
Deflector to ceiling distance	6 - 14" (152 a 355 mm) per NFPA 5 - 14" (127 a 355 mm) per FM
Center line of thermal sensing element to ceiling distance	4 - 13" (102 a 330 mm) per FM
Maximum / Minimum working pressure	175 psi (12,1 bar) / 7 psi (0,48 bar)
Finish	Bronze

Data sheet:	22
REV:	00

OPERATION:

The ESFR sprinkler model AG-17 uses a link which make the rest of the items to be in tension which prevent from the water output, maintaining the assembly in tension. When the temperature rate is approached, the fusible melts and the rest of the items separate, allowing the sprinkler activation and the water flow to exit.

INSTALLATION:

Model AG-17 sprinklers are designed for installation as specified in NFPA 13. They must also be installed with the Model J1 Sprinkler Wrench specifically designed.

The sprinkler joint can be obtained with a torque of 14-20 ft-lbs (19-27,1 N-m). Do not tighten sprinklers over maximum recommended torque. It may cause leakage or impairment of these sprinklers.

TEMPERATURE RATING:

Classification	Nominal Temperature		Maximum Ambient Temperature		Link Color	Frame Color
	°F	°C	°F	°C		
Ordinary	165	74	100	38	Black	Uncolored
Intermediate	212	100	150	66	White	White

DIMENSIONS:

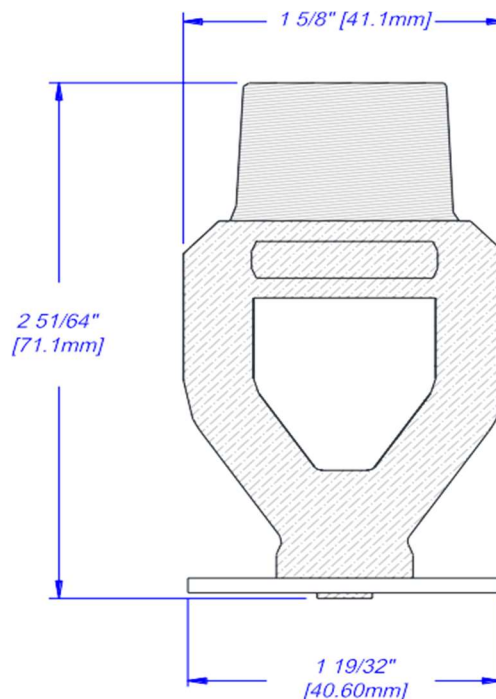

Data sheet:	22
REV:	00