

STORAGE

Control Mode Quick Response Sprinkler Pendant and Upright



DESCRIPTION:

The upright sprinkler model AG-XLO is a center strut, solder in compression, extra large orifice sprinkler that has been designed for storage and non-storage applications.

The Model AG-XLO sprinkler is intended for use as a standard response standard spray sprinkler in hydraulically designed sprinkler systems with a minimum pressure of 7 psi (0.5 bar) in accordance with the area/density curves of NFPA 13 or in accordance with FM Property Loss Prevention Data Sheets. The Model AG-XLO sprinkler is not an "ESFR" sprinkler.

TECHNICAL DATA:

Nominal "K" Factor	11,2 (160 metric)
Thread Size	3/4" NPT (R3/4)
Minimum spacing between sprinklers	6 ft (1,8 m)
Temperatures	165°F (74°C) 212 °F (100°C)
Minimum Operating Pressure	7 psi (0,5 bar)
Finishes	Bronze

OPERATION:

The sprinkler model AG-XLO QR from AG Fire Sprinkler uses a central link with compression weld. The fusible is captured in the capsule cylinder through a stainless steel ball. When the fusible melts, the ball displaces through the cylinder, allowing the cylinder to separate from the central link. When it occurs, the lever is liberated and it removes from the sprinkler, this way all the operating items unblock the water way and allow the deflector to distribute the water discharge.

INSTALLATION:

Model AG-XLO QR sprinklers are designed for installation as specified in NFPA 13. They must also be installed with the Model AG3 Sprinkler Wrench specifically designed.

The sprinkler joint can be obtained with a torque of 14-20 ft-lbs (19-27,1 N-m). Do not tighten sprinklers over maximum recommended torque. It may cause leakage or impairment of these sprinklers.

Data sheet:	19
REV:	00



TEMPERATURE RATING:

Classification	Nominal Temperature		Maximum Ambient Temperature		Frame Color
	°F	°C	°F	°C	
Ordinary	165	74	100	38	Un colored
Intermediate	212	100	150	66	White

DIMENSIONS:

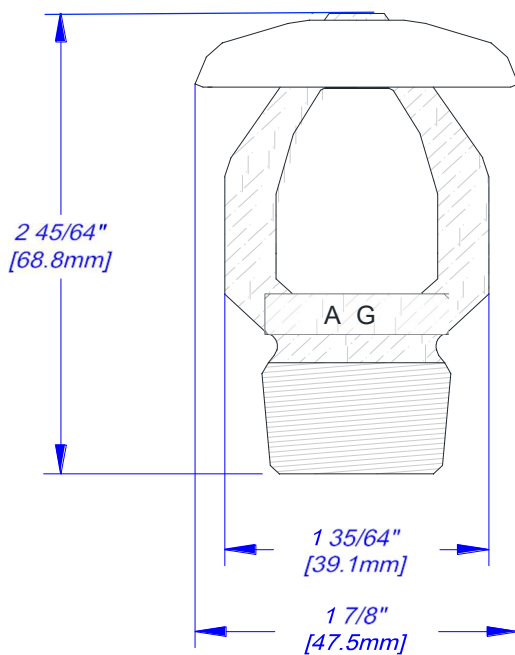

UPRIGHT

PENDANT

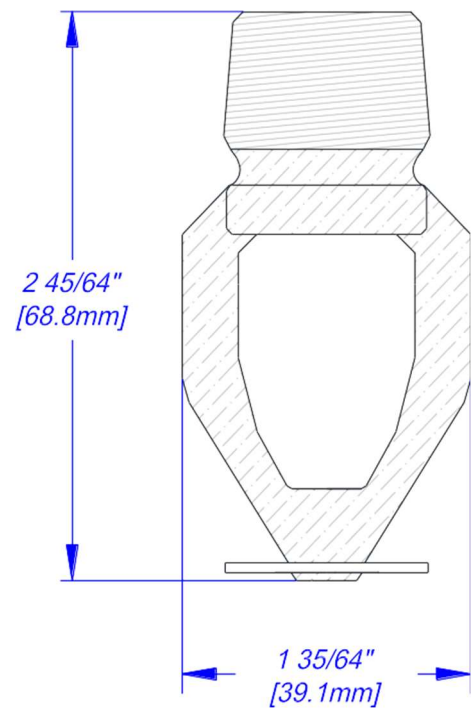

Data sheet:	19
REV:	00