

# TECNICAL SHEET BI-A

■ ■ Bocchelli acqua/schiuma autoaspiranti  
cod. BI-A

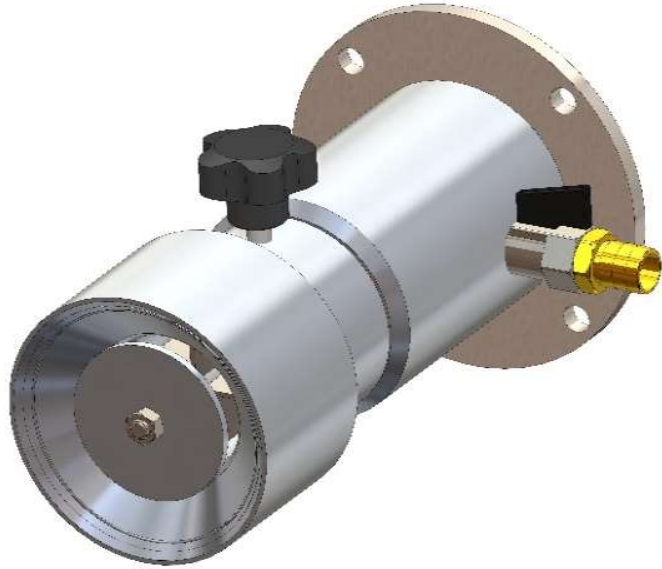

## Caratteristiche tecniche

Ingresso: flangia standard Ø160mm, filetto F GAS 2"1/2 oppure altri tipi di attacchi su richiesta

Regolazione getto pieno o nebulizzato ad ampio raggio

Range miscelazione: 3% - 6%

Tubo di aspirazione: 150 cm gomma spiralata

Pressione minima di utilizzo: 5,0 bar

## Materiali

Corpo: bronzo (T5), ottone (T1), lega leggera (V1),

inox AISI 304 (B2), inox AISI 316 (B3)

Flange: acciaio al carbonio (A1), inox AISI 304 (B2),

inox AISI 316 (B3)

## Finitura

Finitura naturale, solo per parti in acciaio al carbonio verniciatura colore rosso RAL 3000

■ Self-sucking water/foam nozzles cod.  
BI-A



## Technical data

Inlet: standard flange Ø160mm, threaded F GAS 2"1/2 or other connections on request

Adjustable full stream and wide angle fog

Mixing range: 3% - 6%

Aspiration pipe: 150 cm spiral hose

Minimum operating pressure: 5,0 bar

## Materials

Body: bronze (T5), brass (T1), light alloy (V1),

s.s. AISI 304 (B2), s.s. AISI 316 (B3)

Flange: carbon steel (A1), s.s. AISI 304 (B2),

s.s. AISI 316 (B3)

## Finish

Finish natural, only carbon steel parts painting colour red RAL 3000



# FIRING

[www.firing.it](http://www.firing.it)



N° SCHEDA	14
PRODUCT COD	BI-A
REV.	0

# TECNICAL SHEET BI-A

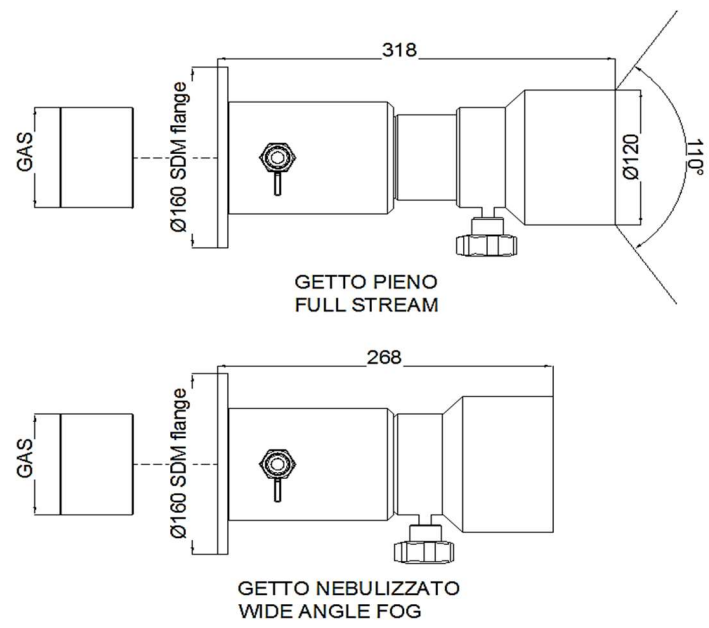

Model Model	Portate / Flow (lt/min)						
	Pressioni / Pressures (bar)						
	1 (K)	5	6	7	8	9	10
BI-A	189	425	465	500	535	570	600
	378	845	925	1000	1070	1135	1195
	567	1270	1390	1500	1605	1700	1795
	756	1690	1850	2000	2140	2270	2390
	945	2115	2315	2500	2675	2835	2990
	1134	2535	2775	3000	3205	3400	3585
	1512	3380	3705	4000	4275	4535	4780
	1890	4225	4630	5000	5345	5670	5975
2270	5070	5555	6000	6415	6805	7170	



www.firing.it



N° SCHEDA	14
PRODUCT COD	BI-A
REV.	0

# TECNICAL SHEET BI-A



GITTATA - GETTO PIENO / RANGE - FULL JET

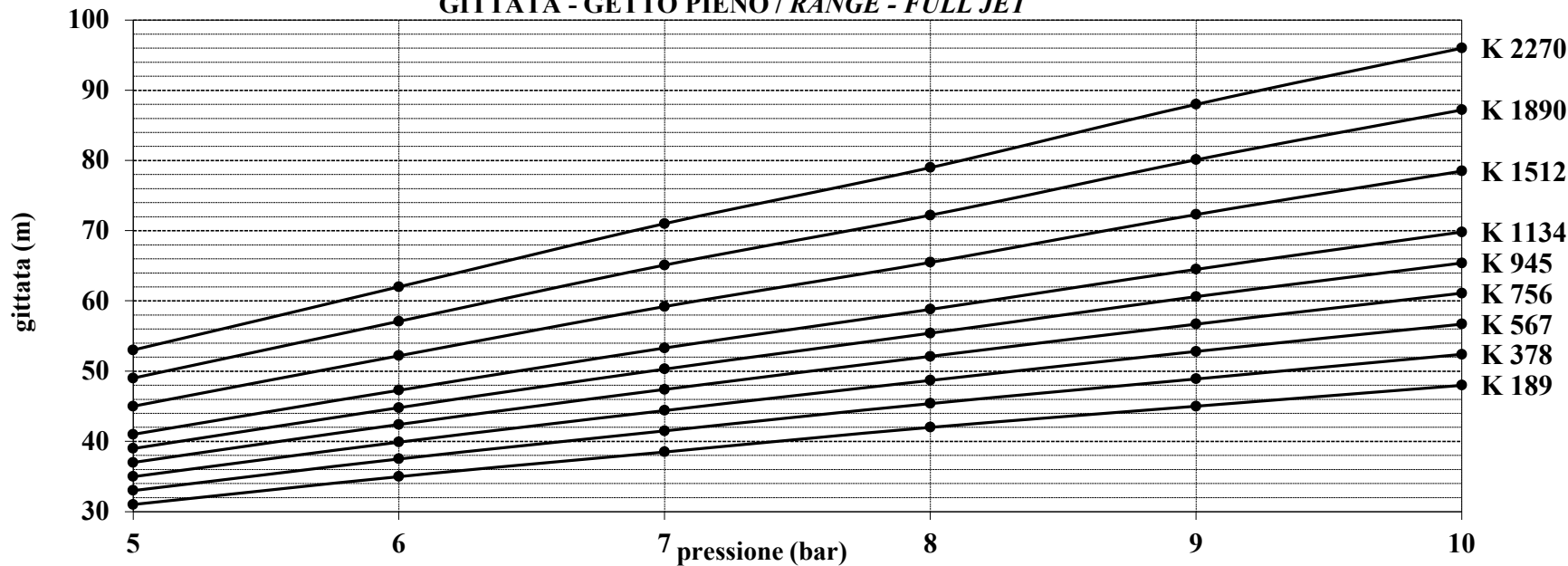

GITTATA - GETTO FOG 110° / RANGE FOG JET 110°

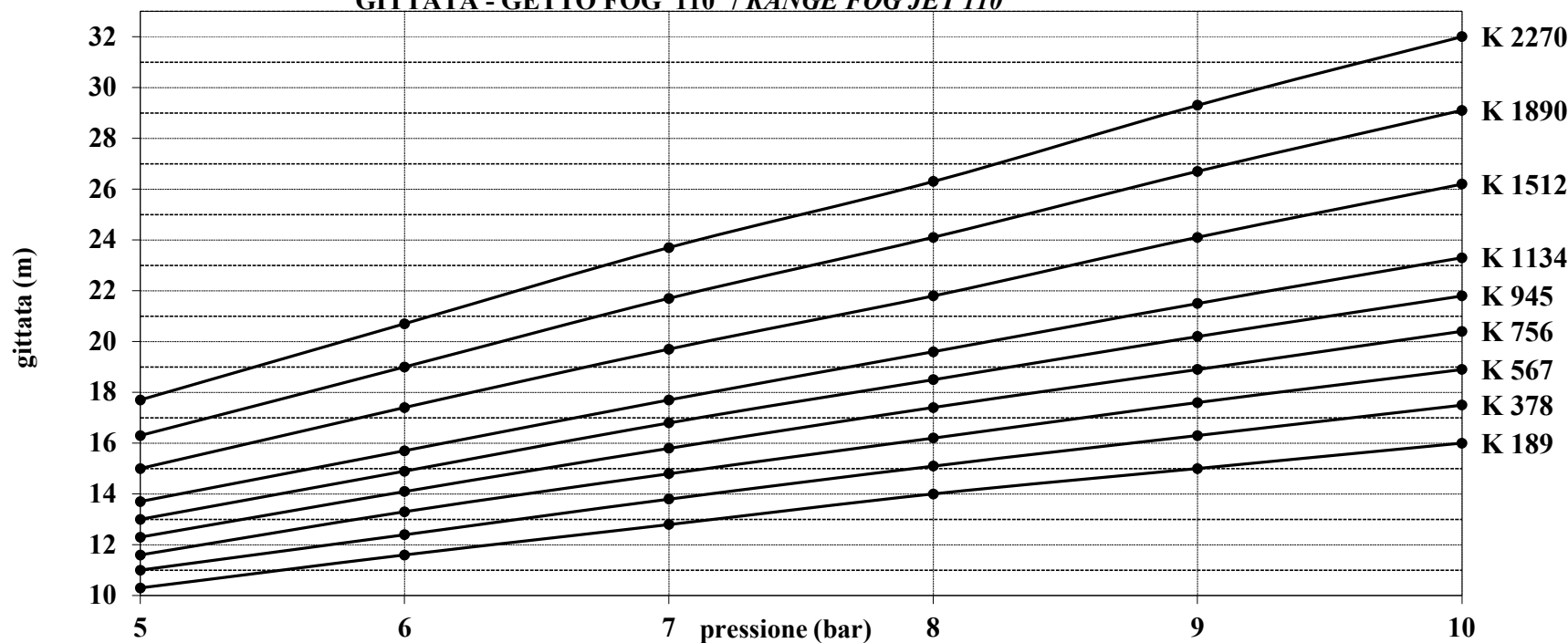

# FIRING

www.firing.it



N° SCHEDA	14
PRODUCT COD	BI-A
REV.	0

# TECNICAL SHEET BI-A



Il presente prodotto è conforme alle specifiche tecniche indicate nelle norme:  
UNI EN 14816:2009 Installazioni fisse antincendio – Sistemi spray ad acqua a diluvio fissi, interni e esterni a edifici, impianti industriali e altre strutture  
UNI EN 13565-2:2009 Sistemi fissi di lotta contro l'incendio - Sistemi a schiuma  
NFPA 11:2010 Standard for Low, Medium, and High - Expansion Foam

NFPA 15:2007 Standard for Water Spray Fixed Systems for Fire Protection

NFPA 16:2011 Standard for the Installation of Foam -Water Sprinkler and Foam -Water Spray Systems

FIRING S.r.l. si riserva il diritto di apportare modifiche ai prodotti al fine di migliorarne le prestazioni o che si rendano necessarie ai fini della sicurezza, per soddisfare le specifiche di prodotto e/o per conformarsi ai requisiti di legge, norme o regolamenti applicabili.



This product complies with the technical specifications indicated in the standards:

UNI EN 14816:2009 Installazioni fisse antincendio – Sistemi spray ad acqua a diluvio fissi, interni e esterni a edifici, impianti industriali e altre strutture  
UNI EN 13565-2:2009 Sistemi fissi di lotta contro l'incendio - Sistemi a schiuma  
NFPA 11:2010 Standard for Low, Medium, and High - Expansion Foam

NFPA 15:2007 Standard for Water Spray Fixed Systems for Fire Protection

NFPA 16:2011 Standard for the Installation of Foam -Water Sprinkler and Foam -Water Spray Systems

FIRING S.r.l. reserves the right to make changes to the products in order to improve their performance or to become necessary for safety purposes, to meet product specifications and / or to comply with applicable legal requirements, rules or applicable regulations.



[www.firing.it](http://www.firing.it)



N° SCHEDA	14
PRODUCT COD	BI-A
REV.	0